

Il progetto FUSS e la creazione di valore pubblico.

Paolo Dongilli – Progetto FUSS
Direzione Istruzione e Formazione Italiana
Provincia Autonoma di Bolzano
<https://fuss.bz.it>



26 giugno 2023 – Incontro con le scuole del Lazio

eSüdtirol 2004 - 08

Piano d'azione per lo sviluppo della società dell'informazione in Alto Adige

Link: https://civis.bz.it/downloads/piano_di_azione-es_dtirol_v_3_1_.0.pdf

3.12. Utilizzo più diffuso del software libero	62
3.12.1. Introduzione di soluzioni di software libero nella pubblica amministrazione.....	63
3.12.2. Estensione dell'uso di soluzioni di software libero nelle attività didattiche nelle scuole della provincia di Bolzano.....	64
3.12.3. Il software libero come criterio di sostegno all'innovazione nel mondo delle imprese.....	64
3.13. Creazione di centri di competenza.....	65
3.13.1. Istituzione di centri di competenza per la tutela dei dati ed il software libero	66

2005 - Nasce il progetto FUSS



FUSS

FREE UPGRADE IN
SOUTH TYROL'S SCHOOLS

Servivano persone coraggiose





Topologia di una rete FUSS

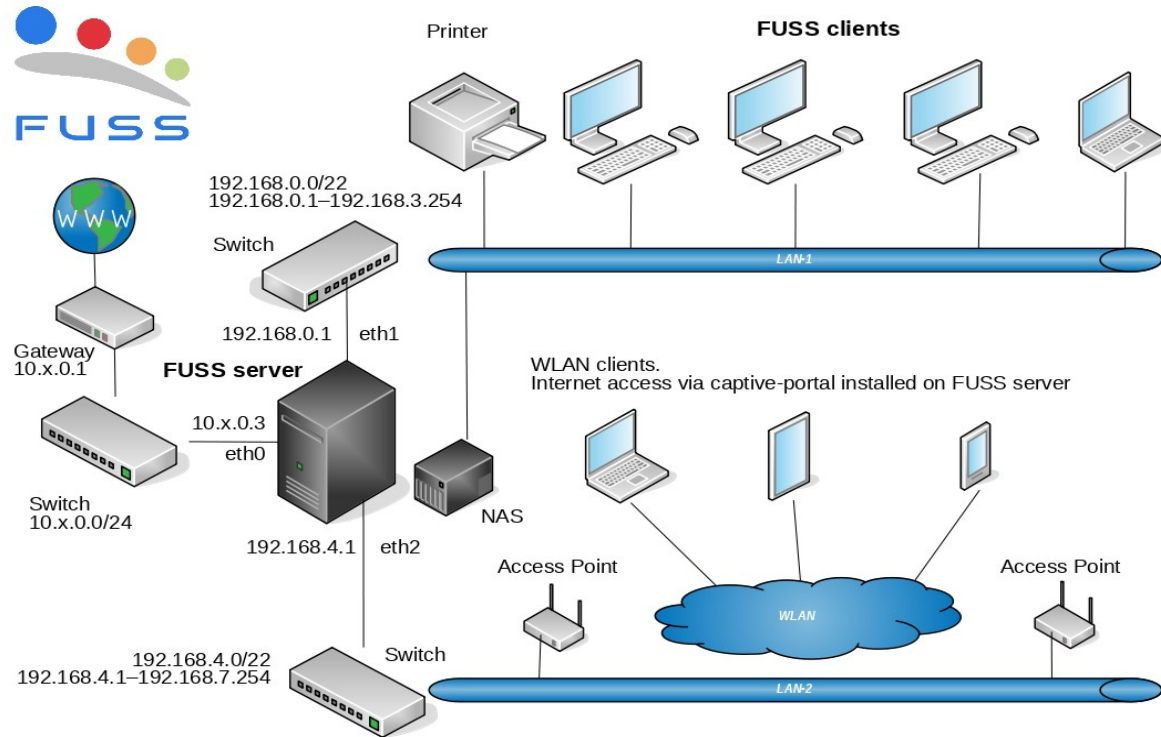

FUSS nelle scuole della Provincia di Bolzano



Laboratorio informatico Scuola secondaria di II grado “Ada Negri”, Bolzano



I numeri di FUSS

Scuole pubbliche in lingua italiana in Provincia di Bolzano

17.000 studenti

1.900 insegnanti

74 plessi scolastici

4.500 PC e notebook

64 server

~200 software didattici

Organizzazione Progetto FUSS

- **Nucleo FUSS:** Intendenza scolastica italiana **Paolo Dongilli, Andrea Bonani e Claudio Cavalli** e la collaborazione dell'isp. **Fabio Furciniti.**

info@fuss.bz.it - **0471 411371**

- **Tecnici FUSS:** Ripartizione Informatica per manutenzione server, PC e reti: 8 tecnici (**6 FTE**)
- **Referenti FUSS:** circa 74 docenti con ruolo di referente tecnico

FUSS alla Scuola di Musica “Vivaldi”



FUSS al Liceo Scientifico “Toniolo”



FUSS all'Istituto "E. Cornaro" di Jesolo



https://fuss.bz.it/post/2020-09-20_istituto-cornaro-jesolo/

FUSS al Liceo “N. Rodolico” di Firenze



<https://www.lsnr.it>

FUSS nelle scuole dell'infanzia (III Circolo Bolzano)



FUSS nelle scuole dell'infanzia



https://fuss.bz.it/post/2022-12-15_approccio-digitale-scuola-infanzia/

FUSS per lo smart working



FUSS: crea valore pubblico



REPUBBLICA
DIGITALE



**Digital Skills and
Jobs Coalition**



Public Money

Public Code

publiccode.eu



FÜR EIN NACHHALTIGES SÜDTIROL
PER UN ALTO ADIGE SOSTENIBILE

**South-Tyrolean
Network for
Sustainability**

it **Developers Italia**
Sviluppiamo i servizi pubblici, insieme



**open source
initiative**

Il valore dell'open source per il Governo italiano



Il valore dell'open source per un'Europa digitale indipendente e competitiva

Uno studio della Commissione Europea fa luce sulle potenzialità economiche dell'open source e raccomanda agli Stati Membri investimenti dedicati

<https://innovazione.gov.it/notizie/articoli/il-valore-dell-open-source-per-un-europa-digitale-indipendente-e-competitiva/>

**Free
Open
Source
Software**

**Standard
aperti**

**Contenuti
aperti**

**Libero
accesso**

Condivisione della conoscenza

Quali tecnologie vogliamo a scuola?

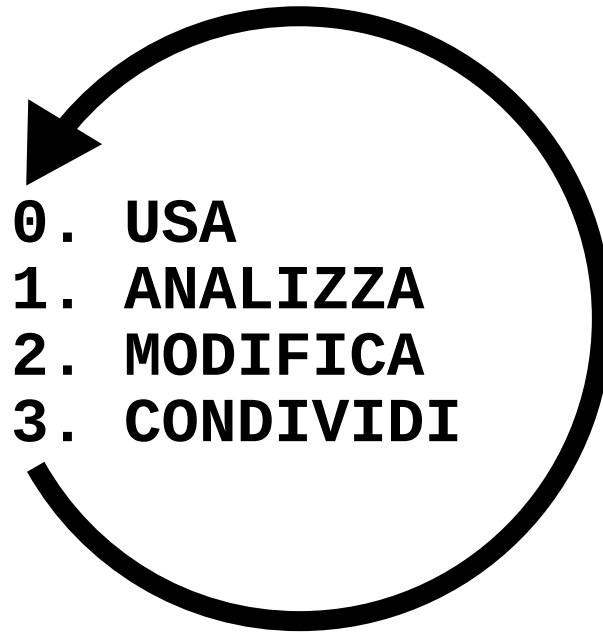

Quali tecnologie NON vogliamo a scuola?

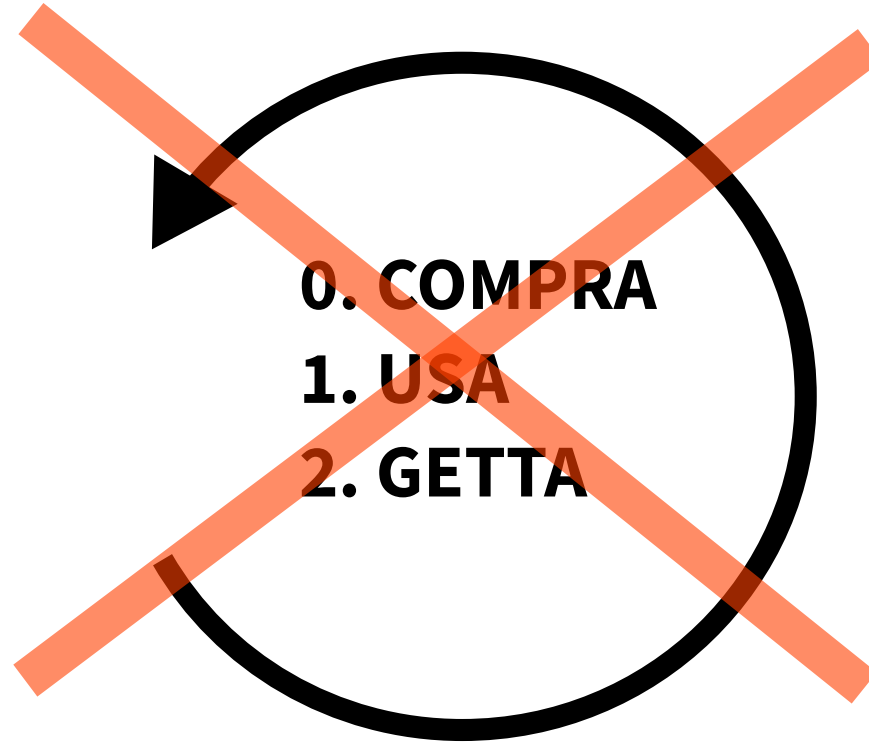

Cibo in scatola ...



... o ingredienti e ricetta?



I nostri studenti sanno fare di più che cliccare icone colorate



Devono avere la possibilità di aprire il cofano!

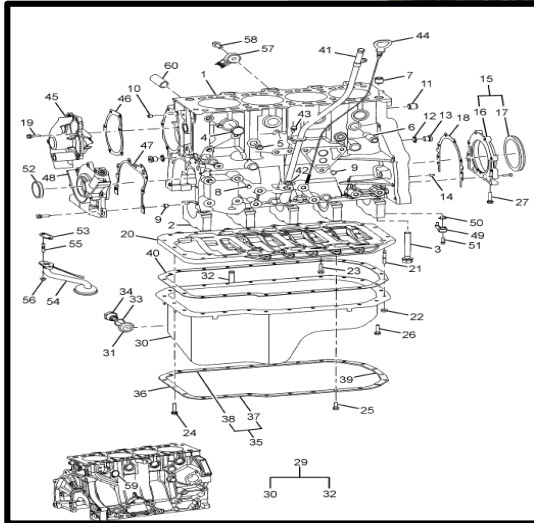

Alternanza scuola-lavoro



- Marco Marinello
- Davide Nobile
- Hamza Jamil
- Samuele Da Col
- Manuel Chiocchetti
- Alberto Iovino

- Massimiliano Mola
- Lorenzo Galati
- Manpreet Singh
- Matteo Azzolini
- Daniel Dal Bosco
- Leonardo Reyna Salas
- Paolo Bagozzi

- debugging & code enhancement
- new software
- documentation
- FUSS for armv7 architecture
- digital signage
- hardware reuse & circular economy
- sensoristica ambientale

Musica Scuola Vivaldi

Avvisi	Corso	Docente	Aula	Ora inizio	Ora fine
Nessun avviso	canto moderno	Carlini Roberta	3.5	08:40	17:15
	canto moderno	Carlini Roberta	3.5	08:40	17:15
	organo e clavicembalo	Facchin Marco	2.5	09:00	20:30
	chitarra - musica d'insieme	Eccher Giuliano	2.5	09:00	11:15
	informatica musicale	Popoli Tiziano	2.6	09:00	22:00
	Orchestra Over	Degano Anita	2.8 Vivaldi	09:00	12:00
	canto lirico	Lazareva Oksana	3.6 Mozart	09:00	16:00
	flauto dolce e traversiere	Lupo Luigi	3.7	09:00	13:00
	canto lirico	Gigli Giovanna	3.9	09:00	13:00

14:37
Domenica, 7 novembre

Orario lezioni

Eventi

Dagli ai giorni ai giorni invisibili
Cosa è stato del campo del mondo al 500 secolo

powered by **FUSS**

Alternanza scuola-lavoro ed Economia Circolare

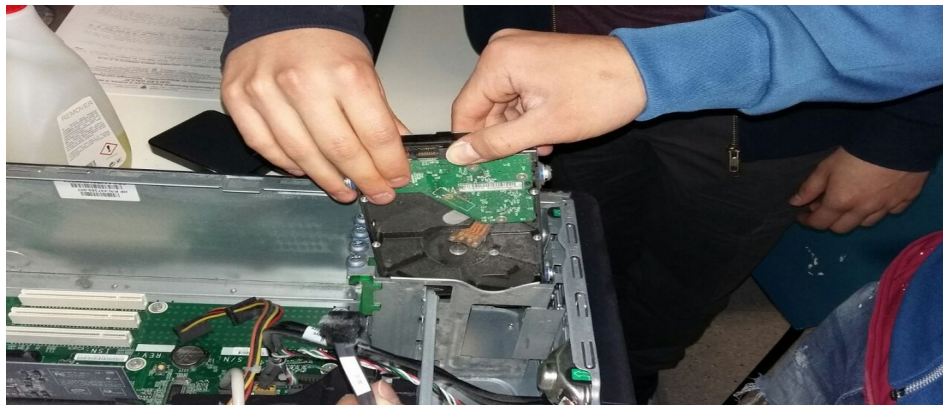

Catalin Bottazzi
Davide Trevisan

seguiti da **Fabio**
Ferraris



Riuso dell'hardware è sostenibilità vs obsolescenza programmata & usa e getta

Riutilizzo di PC completi ed ancora funzionanti

Il Parlamento europeo chiede l'adozione di **misure** anche **contro l'obsolescenza programmata dei prodotti**, strategia propria del modello economico lineare.



Il progetto SchoolSwap ha consegnato più di 600 PC

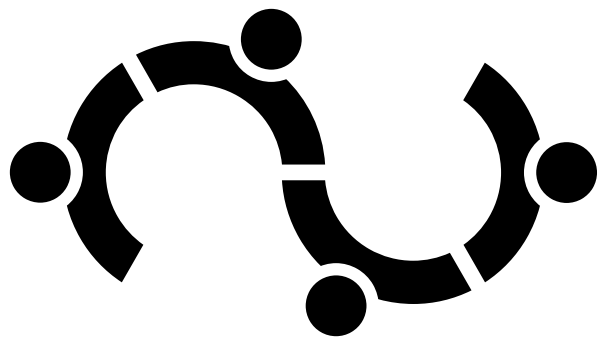

SCHOOLSWAP

<https://schoolswap.bz.it/>

Un PC sostenibile per studiare e lavorare.



Ci penso io allo sfondo!

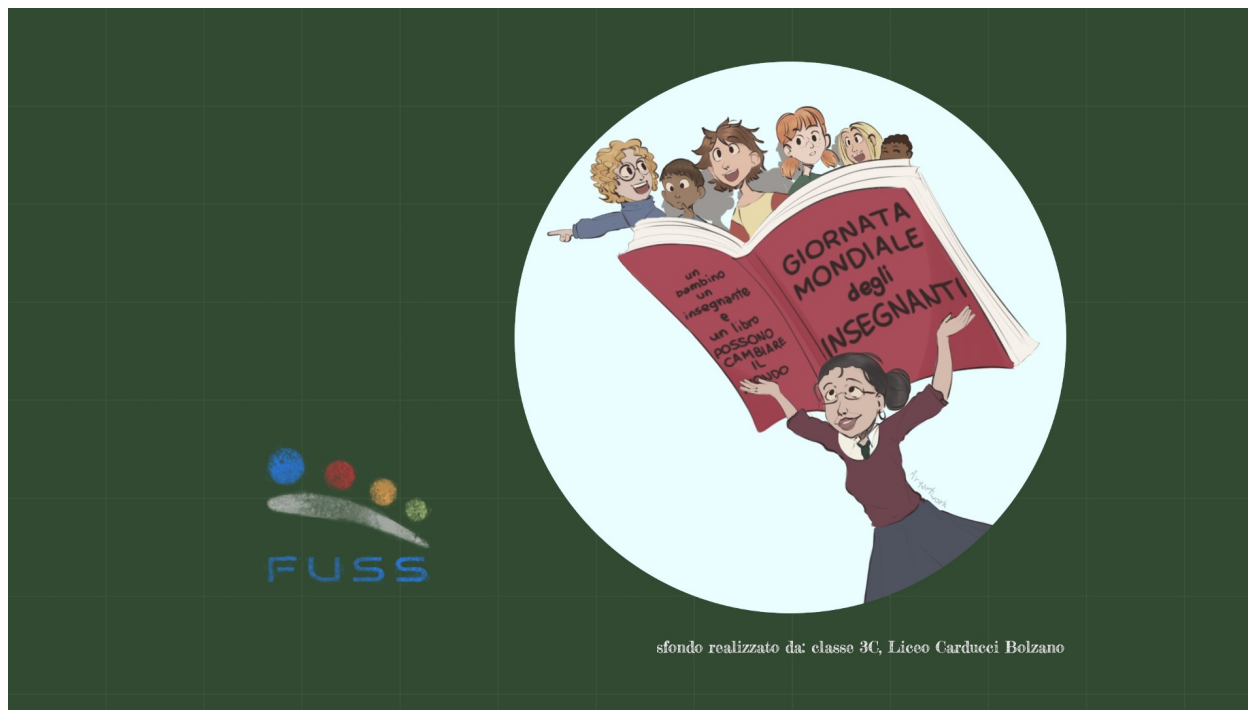

Classe 3C, Liceo "G. Carducci", Bolzano

Quasi 200 pacchetti software in FUSS – ciascuno è un dono



<https://www.fuss.bz.it/page/doc/>

Esempi di Software Libero

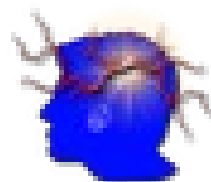
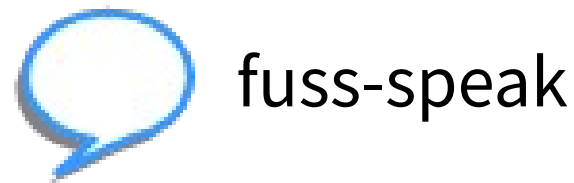
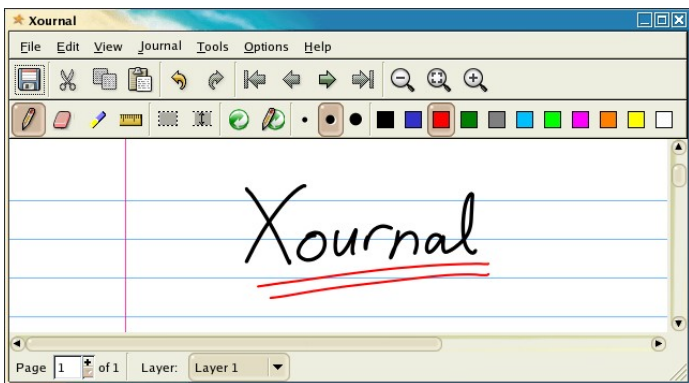

View Your Mind



FET per gli orari scolastici

View teachers timetable

Bárbaro
Ortiz
Arturo
Adrián
Danilo
Ernesto
Leyanis
Diamiry

Teacher is not available 100% in this slot

Lock/unlock
Time Space
Both
Help Close

Ernesto

	Lunes	Martes	Miércoles	Jueves	Viernes	Sábado
08:00	M2 C G101 A1	-x-	M2 C G103 A3	-x-	M2 C G102 A2	
09:45	M2 C G103 A3	-x-	M2 C G102 A2	-x-		
11:30	M2 C G102 A2	-x-	M2 C G101 A1	-x-	-x-	
13:30	-x-	-x-	-x-	-x-	M2 C G101 A1	
15:15	-x-	-x-	-x-	-x-	M2 C G103 A3	
17:00	-x-	-x-	-x-	-x-	-x-	-x-

<https://www.lalescu.ro/liviu/fet/>

Acquistando Software Libero la PA crea valore pubblico

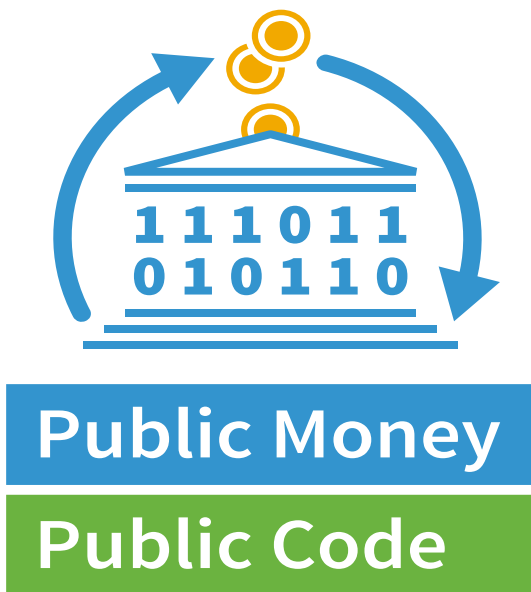

fsfe.org

<https://publiccode.eu/>

Lavorare con il modello del Software Libero

truelite

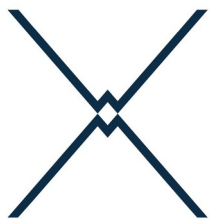

Marco Marinello

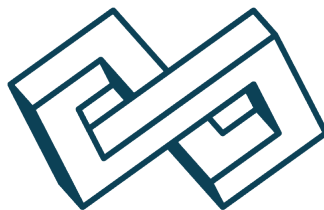

CONTINUITY



Aspetti economici

Anno	Descrizione	Costi
2005	<u>initial migration + development</u>	€ 316.815,00
2006	<u>migration + maintenance</u>	€ 125.750,00
2007	<u>dev + maintenance</u>	€ 8.000,00
2008	<u>dev + maintenance</u>	€ 23.800,00
2009	<u>dev + maintenance</u>	€ 16.280,00
2010	<u>dev + maintenance</u>	€ 15.600,00
2011	<u>dev + maintenance</u>	€ 11.699,40
2012	<u>dev + maintenance</u>	€ 15.846,89
2013	<u>dev + maintenance</u>	€ 5.368,33
2014	<u>dev + maintenance</u>	€ 15.168,24
2015	<u>dev + maintenance</u>	€ 17.100,41
2016	<u>dev + maintenance</u>	€ 0,00
2017	<u>dev + maintenance</u>	€ 35.136,00
2018	<u>dev + maintenance</u>	€ 18.060,00
2019	<u>dev + maintenance</u>	€ 42.667,00
2020	<u>dev + maintenance</u>	€ 14.640,00
2021	<u>dev + maintenance</u>	€ 26.137,77
2022	<u>dev + maintenance</u>	€ 37.453,51
2023	<u>dev + maintenance</u>	€ 10.065,00
	TOTALE	€ 755.587,55

In **18 anni (2005-2023)** abbiamo investito **€ 755.588**.

Nel corso degli ultimi **8 anni (2016-2023)**, grazie al software libero, le spese sono state inferiori ad un anno di licenze Microsoft.

€ 184.158 vs € 200.000

Piattaforme web disponibili

Moodle F.U.S.S.

Home



F.U.S.S.
Piattaforma di e-learning (Moodle)
per i docenti ed alunni delle scuole
della Provincia Autonoma di Bolzano

Corsi

- › Generale
- › Formazione Docenti
- › CITTADINANZA E COSTITUZIONE
- › Formazione Professionale
- › Liceo Scientifico Torricelli
- › Liceo classico Carducci
- › I.I.S.S. Galilei - Bolzano
- › Licei Merano Gandhi
- › ITE Battisti Bolzano
- › Liceo Dante Alighieri - Bressanone
- › ITE Falcone e Borsellino - Bressanone
- › Liceo Toniolo
- › Liceo Pascoli
- › ITG Delai Bolzano
- › Istituto Marcelline - Bolzano

Navigazione

- › Home
- › Informativa privacy
- › Corsi

Informativa sulla Privacy

Amministrazione: Nucleo Fuss



Cos'è il cloud?



Quale cloud? Quello che usano gli altri? Pericoloso!



Checklist per quando si vuole usare “il cloud”

☑ Sostenibile?

- Basato su software libero
- Usa standard/protocolli aperti

☑ Interoperabile/Federato?

☑ Verificabile?

☑ Sovrano?

☑ a norma del GDPR?

Quale cloud per le scuole?



Castel Appiano -
Schloss Hocheppan (1130)

Appiano-Eppan (BZ)

FUSS è sostenuto da enti, associazioni, aziende



Grazie per la vostra attenzione

Per ulteriori informazioni:

<http://fuss.bz.it>

info@fuss.bz.it



FUSS

Digital Sustainability at School

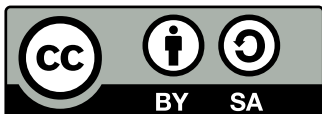

All text and image content in this document is licensed under the Creative Commons Attribution-Share Alike 4.0 License (unless otherwise specified). "LibreOffice", "The Document Foundation", Moodle, BigBlueButton, Open Source Initiative are registered trademarks. Their respective logos and icons are subject to international copyright laws. The use of these therefore is subject to the trademark policy.